

**INSTRUCTION MANUAL**  
**McINTOSH MODEL MR-55A**  
**AM-FM TUNER**

(Serial No. 3K001 and up)

**McINTOSH LABORATORY, INC.**  
2 Chambers St. Binghamton, N. Y.  
U.S.A.

## SPECIFICATIONS:

### AM

#### Sensitivity:

1.5 microvolts

#### Selectivity:

Narrow (4 K.C. bandwidth)  $\pm$  10 K.C. from center down 53 D.B.

Medium (13 K.C. bandwidth)  $\pm$  10 K.C. from center down 20 D.B.

Broad (20 K.C. bandwidth)

(Measurements include R.F. and I.F. circuits. The characteristics are substantially unchanged over entire R.F. tuning range.)

#### Bandwidth:

I.F. at 600 K.C. and at 1600 K.C.; 20 K.C.

R.F. at 600 K.C. 21 K.C.; at 1600 K.C.; 23 K.C.

#### Audio Bandwidth:

Broad Position  $\pm$  3 D.B.; 20 to 9.5 K.C.

Medium Position  $\pm$  3 D.B.; 20 to 6.5 K.C.

Narrow Position  $\pm$  3 D.B.; 20 to 2.0 K.C.

#### Sensitivity Selector:

Three Positions

#### Whistle Filter:

70 D.B. rejection 10 K.C.

#### Dimensions:

4 $\frac{3}{4}$ " high x 14 $\frac{3}{4}$ " wide x 12" deep

### FM

#### Usable Sensitivity:

3 Microvolts at 100% modulation ( $\pm$  75 K.C. Dev.) for less than 3% total noise and distortion I.H.F.M. standards.

#### Capture Ratio:

1 to 0.8

#### I.F. Bandwidth

200 K.C.; Flat on Top

#### I.F. Transformers:

Mechanically captive

#### Limiters:

Two

#### Limiter and Detector Bandwidth:

2 Megacycles

#### Frequency Response:

$\pm$  3 D.B.; 20-20,000 cycles

#### A.F.C.:

Separate detector; strong, distortion free, completely variable

#### Drift:

$\pm$  30 K.C. without A.F.C.; negligible with A.F.C

#### Antenna Input Impedance:

300 ohm balanced; 75 ohm unbalanced

### TUBE COMPLEMENT:

V1—6BK7 F.M. R.F. Amplifier

V2—6AB4 F.M. Mixer

V3—6BA6 1st I.F. Amplifier

V4—6AU6 2nd I.F. Amplifier

V5—6AU6 3rd I.F. Amplifier

V6—6AU6 1st Limiter

V7—6AL5 A.M. Det. and A.V.C

V8—6AU6 2nd Limiter

V9—6BN8 A.F.C. Detector

V10—6U8 F.M. Oscillator and Reactor

V11—6BN8 Squelch Amplifier and Detector

V12—6AB4 1st Audio

V13—12AU7 Audio Output & F.M. Meter

V14—6BA6 A.M. R.F.

VI5—6BE6 A.M. Oscillator and Converter

V16—6BW4 Rectifier

D1 } —IN542 Detector  
D2 }

1847 Pilot Lights (4)

### SIZE:

4 $\frac{3}{4}$  Inches High x 14 $\frac{3}{4}$  Inches Wide x 12 Inches Deep

### WEIGHT:

Tuner Only: 17 Pounds, 3 Ounces; In Shipping Carton: 28 Pounds

## INSTALLATION INSTRUCTIONS FOR THE McINTOSH MR-55A AM-FM TUNER

The McIntosh MR-55A is a superior quality AM-FM Tuner for use in home music systems and professional applications where distortion free reception is needed. Typical professional uses are "off the air" recording, broadcast monitor, rebroadcasting, etc.

A thorough perusal of this instruction manual will give greater enjoyment and better listening. The MR-55A is the finest tuner available and complete familiarity with its functions and operation will result in the outstanding performance you expect from a McIntosh product.

The MR-55A may be mounted in its own cabinet or shelf mounted in a custom cabinet. The tuner has been designed to mount on a shelf rather than hang from the cast tuner panel. Rubber shock mounting feet have been provided to offer the optimum in mechanical isolation from extraneous vibrations.

Enclosed in the instruction manual envelope are two copies of the "TUNER PANEL CUTOUT TEMPLATE" and two copies of the "SHELF MOUNTING TEMPLATE" for mounting the MR-55A. Prepare the cabinet for the mounting of the MR-55A by first cutting the wooden cabinet panel to receive the cast tuner panel.

1. On the back of the wooden cabinet panel make a vertical center line on the exact center of the area in which the tuner will mount. Extend this center line to the shelf.

2. Fold the "TUNER PANEL CUTOUT TEMPLATE" on the "FOLD LINE." The "FOLD LINE" is the line of the top of the shelf on which the tuner will mount.

3. Place the "TUNER PANEL CUTOUT TEMPLATE" in the proper location on the inside of the cabinet with the fold line against the shelf. The template center line should match the center line scribed on the panel in step 1.

4. In the center of the "Cutout Area" on the "Tuner Cutout Template" are two holes marked "LOCATION HOLES." Carefully and accurately drill these two holes with a 5/32 inch drill.

5. Transfer the "TUNER PANEL CUTOUT TEMPLATE" to the front of the wooden cabinet panel. Match the "LOCATION HOLES" for the proper positioning of the template. Proceed with marking the location of the six holes and the outline of the cutout on the front of the wooden cabinet panel.

**IMPORTANT: DRILL THE FOUR 3/16 INCH AND THE TWO 5/32 INCH HOLES BEFORE CUTTING OUT THE TUNER PANEL HOLE.**

The cast tuner panel has a 1/4 inch overlap to cover the edges of the cutout in cabinet panel.

Next prepare the shelf for mounting the tuner.

1. Measure the thickness of the wooden cabinet panel.

2. "FOLD LINES" have been supplied on the "SHELF CUTOUT TEMPLATE" for standard panel thickness up to one inch. Fold on correct fold line for your wooden panel thickness.

3. Place the folded edge of the template against the back of the front panel. The template center line must match the center line extended to the shelf in step #1 of the front panel cutout instructions..

4. Carefully mark the locations of the four 1/4 inch holes and the 8 by 10 1/4 inches ventilation hole.

5. Drill and cut out the shelf.

Next prepare the MR-55A for mounting in the cabinet by removing the pressed wood shipping pallet from the bottom of the tuner.

Remove the knobs by gently pulling them toward you. Remove the felt washers.

The cast tuner panel has been attached to the tuner by two angle brackets that are for shipping purposes only. These are removed by unscrewing the four screws (two on each side) that hold the angle brackets to the tuner chassis. (See Fig. 1.) After removing these four screws the tuner panel can be slipped off over the knob shafts.

After removing the tuner panel lay it face down on a protected surface for the following operations.

Remove the four 6/32 screws (one on each corner) that hold the two shipping brackets to the tuner panel.

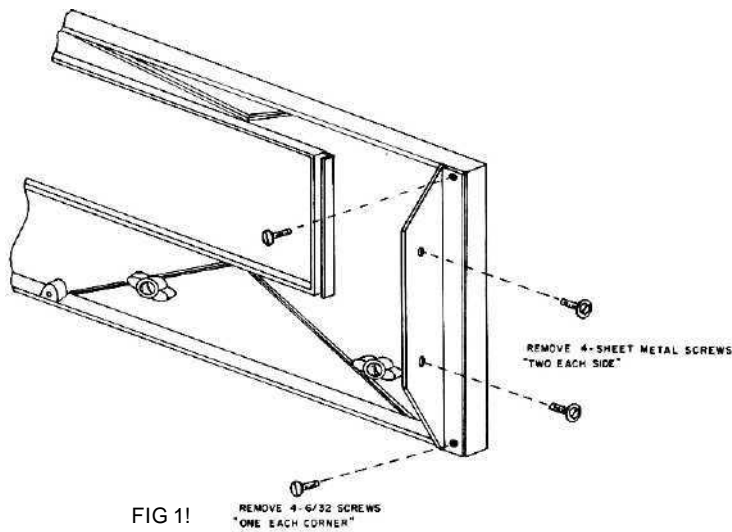

FIG 1!

In the parts bag are six 6/32 x 1 1/4 inches threaded rods. Install these in the six drilled and tapped holes in the back of the tuner panel. (See Fig. 2.)

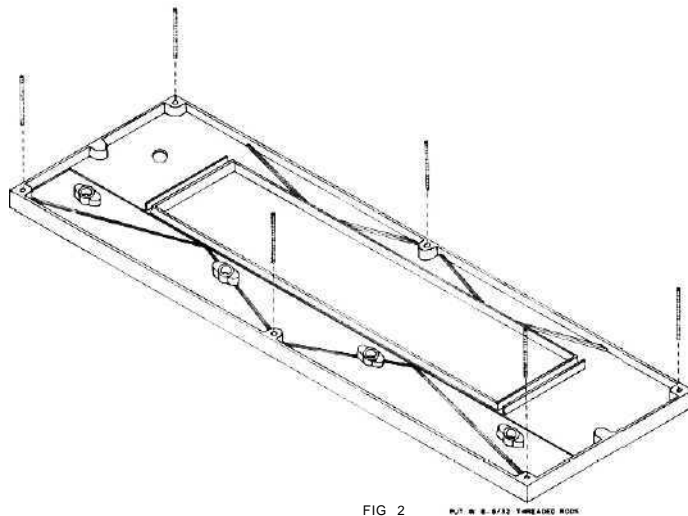

FIG 2 P.N. 6 - 6/32 THREADED RODS

The tuner panel is now ready to be attached to the cabinet. The six threaded-rods are inserted through the two 5/32 inch and the four 3/16 inch holes in the cabinet panel. Secure the tuner panel to the cabinet panel by installing on the rods the 6/32 "KEP" nuts supplied in the parts bag. Bring the nuts up tight with a wrench or nut driver.

The tuner can now be installed in the cabinet. The tuner is secured to the cabinet shelf by the insertion of the four 10/32x3/4 inch screws supplied in the parts bag through the 1/4 inch holes in the shelf.

**IMPORTANT: MAKE SURE THAT THE INNER CHASSIS FLOATS ON THE RUBBER SHOCK MOUNTING FEET, AND DOES NOT CONTACT THE CABINET OR TUNER PANEL.**

Next replace the felt washers and knobs.

Adequate ventilation is essential to the stable operation of any tuner. Do not put a solid back on the cabinet behind the tuner. If the tuner is mounted vertically make sure sufficient ventilation is supplied.

Installation in the L-55 cabinet is done by the same procedure as for installation in a custom cabinet. The cabinets are supplied with the cutouts and holes all prepared.

## CONNECTING PROCEDURE

**FM ANTENNA:** In high signal strength areas a minimum antenna, such as the folded dipole supplied, is all that is needed for local reception. Some care should be used in locating the folded dipole in a position that is free as possible from local noise sources and shielding such as metal roofing and building framework. The dipole should be mounted horizontally, and at 90° to the line of sight path to the transmitting stations.

In fringe areas a good antenna is required. A highly directional broad band antenna used in conjunction with a rotor will result in superior performance in low signal strength areas.

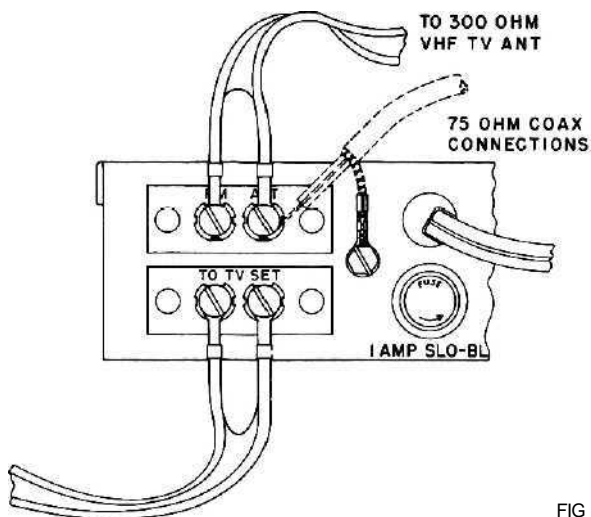

FIG 3

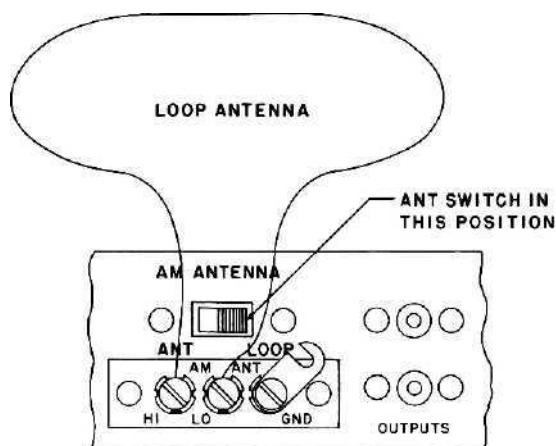

FIG 4

A substitute for the folded dipole can be an existing VHF T. V. antenna. The MR-55A is supplied with an internal switching arrangement that eliminates the need for two set couplers. The VHF T. V. antenna lead-in is connected to the antenna terminals marked "FM ANT." Connect the terminals marked "TO T. V. SET" to the antenna terminals on the T. V. receiver with 300 ohm antenna load. (See Fig. 3.) When the MR-55A selector switch is in either of the "FM" positions the antenna is disconnected automatically from the T. V. receiver. In any other position of the selector switch the antenna is connected to the T. V. set and disconnected from the tuner.

**75 OHM ANTENNA:** Facilities for the connection of a 75 ohm antenna have been provided on the back panel. Connect the center conductor of the 75 ohm antenna lead to the screw, on the FM antenna terminal strip identified by the word "ANT" appearing above the screw. The outer conductor or braided shield is connected to the sheet metal screw adjacent to the antenna terminal board. (See Fig. 3.) Two lugs have been provided in the parts bag to facilitate these connections. The impedance of the antenna system when connected thusly is a perfect 75 ohm match.

Keep the center conductor of the 75 ohm lead as short as possible. Any excessive length from the screw terminal to the place where the shield begins will greatly depreciate the signal to noise ratio.

**A. M. ANTENNA:** Facilities are supplied on the MR-55A for the use of a low impedance loop antenna or a high impedance long wire antenna. AM reception will generally be improved through the use of a properly installed long wire outside antenna.

For locations where an outside antenna is impossible or impractical a 10 foot loop antenna is supplied. The loop is attached between the terminals marked "HI" and "LO" on the "AM. ANT" terminal strip. The "AM. ANT" terminating switch must be in the loop position. (Sec Fig. 4.)

Orientation of the loop is critical. It should be mounted in as large a circle as practical in the vertical plane.

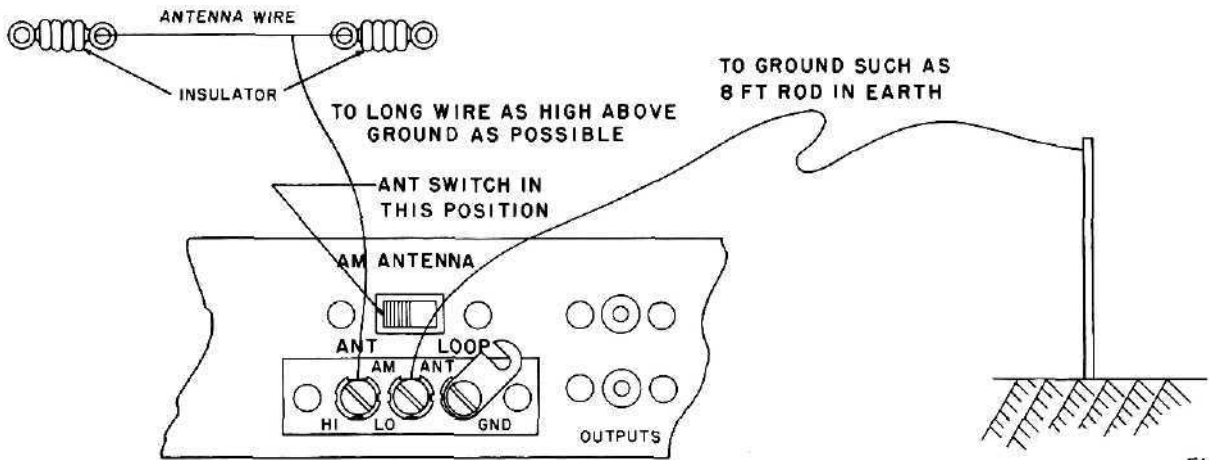

FIG 5

An outside AM antenna is a wire as long as practical, mounted as high as possible above the ground, at right angles to power lines. The lead in should be carefully positioned away from all A. C. lines.

The "ANTENNA" terminating switch must be in "ANT" position when using the outside or long wire antenna.

A good ground can be of assistance in AM reception. A good ground is described as a 1/2 inch rod 6 to 8 feet long driven into the earth. The ground wire is connected to the terminal marked "LO."

If the tuner is connected to an outside ground as described above do not connect any of the other equipment to the same ground to prevent ground loops. Ground loops can cause an increase in hum.

For an alternate ground for use when using a long wire antenna connect the shorting link between terminals marked "LO" and "GND." (See Fig. 5.)

**OUTPUT:** Two pin jacks are supplied on the back panel marked "Outputs." These jacks are in parallel. The output is unbalanced low impedance. Interconnect between either of these jacks and the tuner input of your preamplifier by means of the 6 foot shielded cable supplied with your tuner.

Plug the A. C. cable from the tuner into one of the auxiliary A. C. outlets on the back of the preamplifier.

## **Multiplex Output**

The output on the back of the MR-55A marked "MULTIPLEX OUTPUT" is an unfiltered output for feeding a multiplex adapter.

## **OPERATION**

### **Input Selector**

The input selector has six positions identified as (1) PHONO, (2) A. M. SHARP, (3) A. M. MED, (4) A. M. BRD, (5) F. M. TUNE, and (6) F. M. LISTEN.  
A.M.

As the audio response is increased on A. M. the ambient, man made noises in A. M. reception are increased. Wide audio band width may give superior results on strong local stations and prove unlistenable on distant stations. To increase enjoyment of distance reception the audio band width of your MR-55A has been limited by means of the input selector switch. These limits are on three positions: A. M. Sharp, A. M. Medium, and A. M. Broad.

#### **A. M. Sharp**

The audio response of this position is limited to 20 cycles to 2000 cycles. In the "A. M. SHARP" position distant stations can be received with maximum clarity and minimum noise. Tune to a peak on the signal strength or left meter. The right meter or center of channel meter is only in use on F. M.

#### **A. M. Med.**

The audio response of the A. M. MKD. position is limited to 20 cycles to 6500 cycles. This position is less selective on noise than the "SHARP" position.

#### **A. M. Brd.**

The unrestricted audio response is 20 to 10,000 cycles for maximum A. M. fidelity on strong local stations where noise is not a problem. Tune to either a peak on the signal strength meter, or to the loudest sound.

### **Whistle Filter**

In all A. M. positions there is a 70 DB rejection of the 10 KC whistle.

### **F. M. Tune**

Automatic frequency control (A. F. C.) is disabled and ULTRASONIC MUTING is added for maximum accuracy and ease in tuning. Ultrasonic muting eliminates the annoying noise between stations. In tuning across the band take notice of the complete absence of noise even when approaching a station.

Some stations are received with insufficient signal strength to completely eliminate background noise. The ultrasonic muting circuit has been so designed to permit only listenable signals through. Signals with annoying background noise will be muted. The meters will function normally and indicate the presence of a station. If a desired station is not heard, tune by meter and change the selector switch to "F. M. LISTEN." The station can then be heard. Ultrasonic muting is an exclusive McIntosh development and feature.

If an antenna with a rotor is used the signal strength meter can be of assistance in determining the proper direction to point the antenna. Rotate the antenna until maximum signal strength is registered on the meter. The best signal to noise ratio usually will result at highest indicated signal strength.

### **Muting**

McIntosh designed Ultrasonic muting is an exclusive in your MR-55A. The threshold of muting is adjustable. The control shaft marked "R73" on the top left rear, as you face the front of the tuner, is the muting adjustment.

The muting has been set during final test for any broadcast signals that may be noisy in reception. If less muting is wanted adjust the controls as follows:

1. Turn the input selector to "FM LISTEN."
2. Tune to the noise between stations.
3. Turn the input selector to "FM TUNE."
4. Adjust the "R73" until the noise is heard, then back off until the noise just disappears.

Adjustment by this method results in the greatest number of stations with minimum between station noise.

## **F. M. Listen**

The ultrasonic muting circuit is defeated and A.F. C. added for greatest listening pleasure. McIntosh A. F. C. does not change in any respect the low distortion characteristics of the MR-55A.

## **Volume**

The volume control has at its extreme counter-clockwise rotation the A. C. on-off switch. The switch also controls the A. C. available at the auxiliary A. C. outlet on the back of the tuner. Normal operation for the "VOLUME" control is totally clockwise.

## **A. M. Sensitivity**

The A. M. sensitivity is the greatest at the clockwise position of the switch, the center position is intermediate sensitivity, and the counter-clockwise position is minimum sensitivity.

The clockwise or maximum sensitivity position will deliver the greatest number of stations. Long distant reception will be best in this position. When selecting local stations between station noise can be reduced by using either the minimum or intermediate sensitivity positions which ever is most satisfactory for your location.

## **A. F. C.**

The control identified as "F. M.-A. F. C." is located at the extreme left of the front panel. A. F. C. means automatic frequency control. Its purpose is to lock and hold a station when listening to F. M. The amount of A. F. C. used is variable from none in the counter clockwise rotation to full on in the counter-clockwise rotation.

The amount of A. F. C. used can be varied with conditions. If a weaker station is adjacent to a strong station, too much A. F. C will cause the strong station to come in and completely block the weaker station. By reducing the amount of A. F. C. (rotating the control counter-clockwise) the weaker station will be locked and held.

McIntosh A. F. C. is exceedingly strong. Due to the incomparable McIntosh design the excellent audio quality will not be adversely effected over the entire rotation of the A. F. C. control.

## **Dial**

In addition to the regular A. M. and F. M. identification on the dial a logging scale has been supplied to facilitate repeat tuning of familiar stations.

## **SERVICE INFORMATION**

All McIntosh equipment is designed for long trouble free operation. All components are of highest quality and are conservatively operated. If trouble develops the equipment may be serviced by your franchised dealer, a competent serviceman, or returned to the factory. Equipment will not be accepted at the factory unless factory return authorization is first received.

Much research has been done in our laboratory to overcome the need for alignment and adjustment encountered in high quality tuners. Design parameters have been selected so that major changes can occur in components without degrading the high quality results. Tube replacements seldom require re-alignment. Transformers have been made mechanically captive to prevent misalignment due to vibration and shock. Therefore, the need for adjustment and alignment has been substantially reduced. McIntosh Laboratory, of course, will align and adjust any tuner upon request.

## **GUARANTEE**

We guarantee the performance of this equipment and the mechanical and electrical workmanship to be free of serious defects for a period of 90 days. This guarantee does not extend to components damaged by improper use nor does it extend to transportation to and from the factory.

**McINTOSH LABORATORY, INC**

**2 Chambers Street**

**Binghamton, N. Y., U.S.A.,**

In Canada: Manufactured Under License by McCurdy Radio Industries, Ltd.  
22 Front Street West, Toronto, Canada